

# SANOVO SEC RANGE

## EGGSHELL CENTRIFUGES



### General

The SANOVO Eggshell Centrifuges, SEC-range, are developed for continuous centrifugation and reduction of the volume of eggshells coming from one or more egg breaking machines.

The SEC-range consists of four models:

- SEC 60            60 cases (21.600 eggshells) per hour
- SEC 360        360 cases (130.000 eggshells) per hour
- SEC 560        560 cases (200.000 eggshells) per hour
- SEC 1400      1400 cases (500.000 eggshells) per hour

An inner sieve made of a perforated welded plate ensures an efficient filtering of centrifuged egg liquid.

Safety switches on funnel and doors will stop the centrifuge automatically in case of being opened during operation.

The SEC 60 and 360 models are equipped with easily adjustable pulley V-belt drive. The SEC 560 and 1400 have sturdy tooth belt drives designed for heavy-duty and high capacity operation.

All the centrifuges are entirely made of stainless steel and include a stainless steel cover to protect the motor during cleaning.

### Operational Description

The empty eggshells from the egg breaker are continuously fed into the funnel of the centrifuge where a sieve filters the egg liquid from the eggshells and the crushed eggshells are ejected in the upper part by a built-in screw conveyor.

In a very short time, the sieve, the lifting screw, and the outer casing can easily be dismantled for inspection and cleaning. Special tools for dismantling are included.



### Special features

- 75% reduction of the eggshell volume
- 98% recovery of the egg liquid remaining in the eggshells after breaking
- Continuous operation
- Sturdy design in 100% stainless steel
- Easy cleaning



### Safety and Service

All the SANOVO ENGINEERING products and systems are designed to meet the industry safety standards.

A comprehensive service organisation is always available to assist in the selection of the right maintenance programme or individual spare part.

02 (20. Sep 04)

SANOVO ENGINEERING A/S  
 Thulevej 25-27 P. O. Box 692 - DK-5210 · Odense NV · Denmark  
 Telephone: +45 66 16 28 32 - Telefax: +45 66 16 50 32  
 sanovo@sanovoeng.com - www.sanovoeng.com

Solutions for Food and Egg Processing

# SANOVO SEC RANGE

## EGGSHELL CENTRIFUGES



**SANOVO SEC 60 Centrifuge**

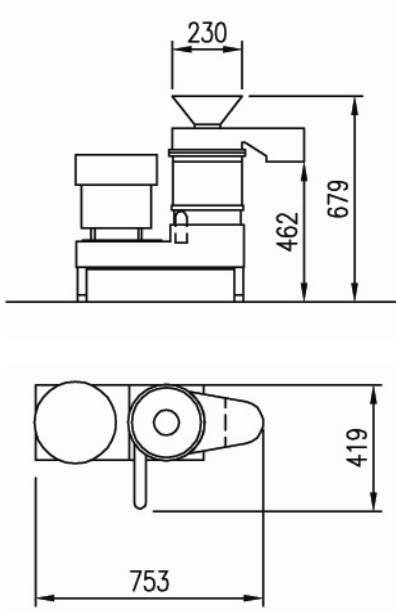

**SANOVO SEC 360 Centrifuge**

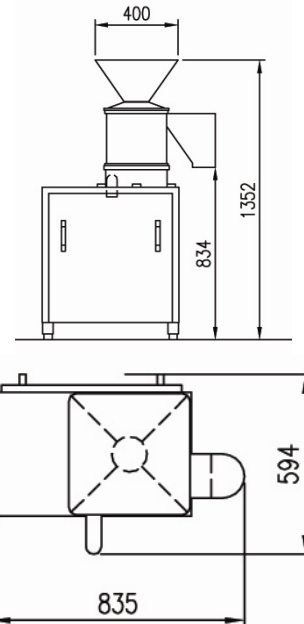

**SANOVO SEC 560 Centrifuge**

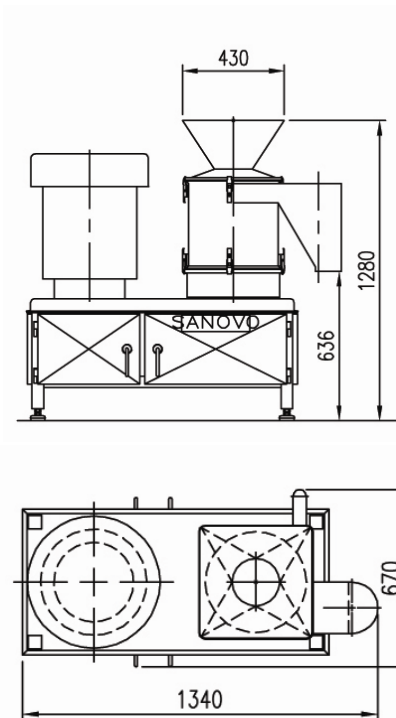

**SANOVO SEC 1400 Centrifuge**

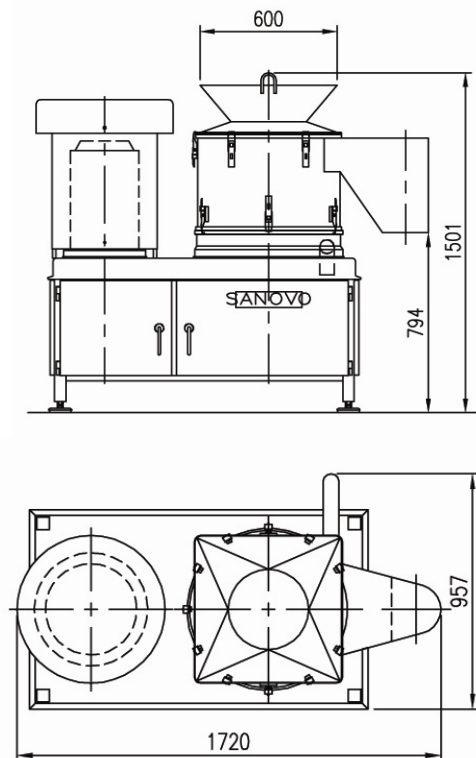

02 (20. Sep 04)

SANOVO ENGINEERING A/S  
 Thulevej 25-27 P. O. Box 692 - DK-5210 - Odense NV - Denmark  
 Telephone: +45 66 16 28 32 - Telefax: +45 66 16 50 32  
 sanovo@sanovoeng.com - www.sanovoeng.com

Solutions for Food and Egg Processing